

Detailed steps for successful installation of an LA-306 furnace. Includes both standard and optional equipment.

1.1 Unpacking the Equipment

1.1.1 Un-banding and Verification

Remove the banding from the shipping container and carefully disassemble. Refer to the Equipment List in this manual and verify the model of your furnace system and good receipt of all options, accessories, and special configurations, which were ordered according to the original purchase order or specification. If you cannot locate a listed item, immediately notify the carrier and Technical Support.

1.2 Location & Initial Installation Work

1.2.1 Machine Inspection

Remove the upper and lower side covers from both sides of the machine. Inspect all lamp connections for soundness and for loose hardware that may have become dislodged during shipment. Inspect the lower electrical compartment for shipping damage, loose connections, or components. Finally, inspect the furnace interior, checking for broken lamps, foreign objects, or any components that may have come loose during shipment. Report any shipping damage immediately to the LCI Furnaces or FurnacePros Technical Support Department.

1.2.2 Machine Label

The furnace label generally appears as in **Figure 1-1 Name Plate** and indicates the maximum power and current draw. Actual operating values are much lower and can be found in 5.1. This label will normally be located near the Power Input either on the side or rear of the Control Enclosure.

SERIAL NO.	1303061XXX	VOLT	220
KW	17.2	PHASE	1
FACTORY ORDER NO.	12-00X	HZ	50
CUSTOMER NAME	XYZ Corp		
LCI FURNACES LOCHABER CORNWALL INC 6745N Eckhoff Street, Ste D, Orange, CA 92868 Phone: 714 935-0302 Fax: 714 935-9809 www.LCIfurnaces.com email: service@furnacepros.com			

Figure 1-1 Name Plate

1.2.3 Machine Location

Furnace Environment Considerations. Location of the machine is important. The furnace environment should be clean and dry, especially if the furnace is to be used for to create low oxygen or other controlled environment. The lower the moisture levels in the room where the furnace is located, the easier it will be to achieve low oxygen and moisture levels in the furnace. Locate furnace away from fans, blowers or other equipment or drafts that can influence atmospheric conditions inside the furnace.

Installing Through a Wall. If installing the furnace through a wall between two rooms, make sure that the room pressures are equalized to avoid influencing the furnace atmosphere.

1.2.4 Lifting and Machine Placement

Furnace Environment. Locate the machine on an unyielding floor in the final installation position so that the access panels along the length of the furnace can be removed for calibration, servicing and maintenance. Lift the machine at the approximate locations shown on the Furnace Arrangement drawing, and slide the shipment skid out from under the machine. Do not attempt to lift the machine at one point or at points other than recommended; failure to follow these instructions invites frame damage and will void the warranty.

Installing Through a Wall. If installing the furnace through a wall between two rooms, make sure that the room pressures are equalized to avoid influencing the furnace atmosphere.

<p>NOTE: The lifting device must extend under the machine and support both sides of the frame structure. See drawing 803-091306 Furnace Arrangement for location.</p>
--

Section 1

1.2.5 Removal of Shipping Restraint Brackets

Large furnaces operating at high temperatures experience considerable growth from thermal expansion. All models are equipped with support slides which allow stress free expansion to take place. To secure the process chamber during shipment, restraining brackets (labeled SHIPPING BRACKET) attach directly between the chamber and frame.

Before operating the furnace first remove the top hex nuts and washers which secure each bracket to the frame. Then remove the shipping bracket and discard or store for use when moving the furnace again.

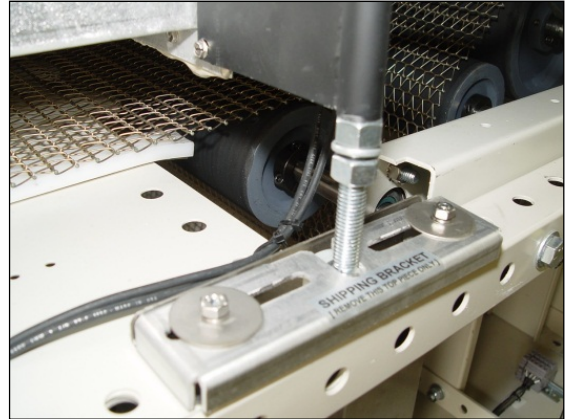

Figure 1-2 Shipping Brackets

WARNING: Failure to remove the top bracket invites structural damage and will void the warranty.

1.2.1 Leveling Machine

Remove the base covers and using an open-end wrench on the screw flats, adjust the leveling feet to level (Figure 1-3) the frame within 0.06 inch overall. Tighten leveling nuts to lock in place.

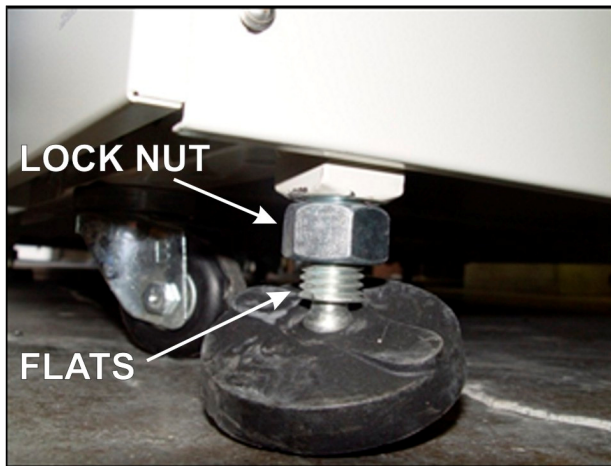

Figure 1-3 Leveling Feet

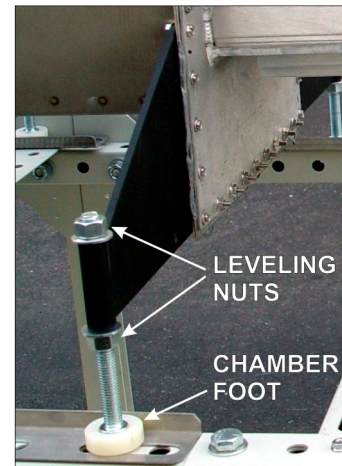

Figure 1-4 Chamber Support Bracket

After the frame is level, adjust the 2 Leveling Nuts (Figure 1-4) on each of the 8 Chamber Support Brackets to 0.06 inch overall. See location of brackets in Figure 1-5. Adjust so that all brackets evenly support the weight of the furnace chamber assembly. Tighten nuts to lock in place.

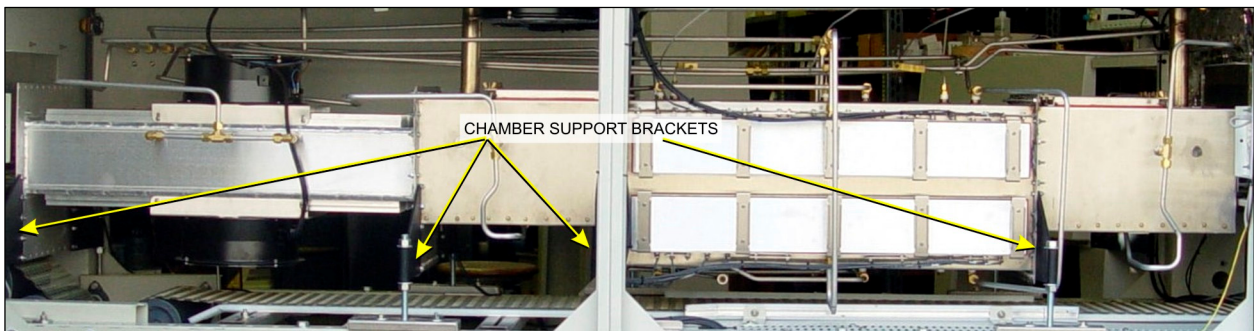

Figure 1-5 Location of Support Brackets

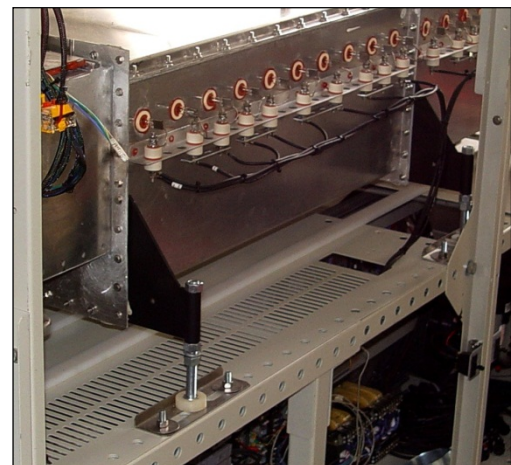

Figure 1-6 Chamber Support Brackets

Section 1

1.2.2 Installation of the Transport Belt

LA-309 furnaces are usually shipped with the belt already properly installed. However, if the furnace is shipped SPLIT or the shipment is expected to be exposed to rough handling or irregular terrain during shipment, the transport belt may have been intentionally left uninstalled to protect the furnace interior. This section can be used for installing the belt on a new furnace or for replacing a damaged or worn belt.

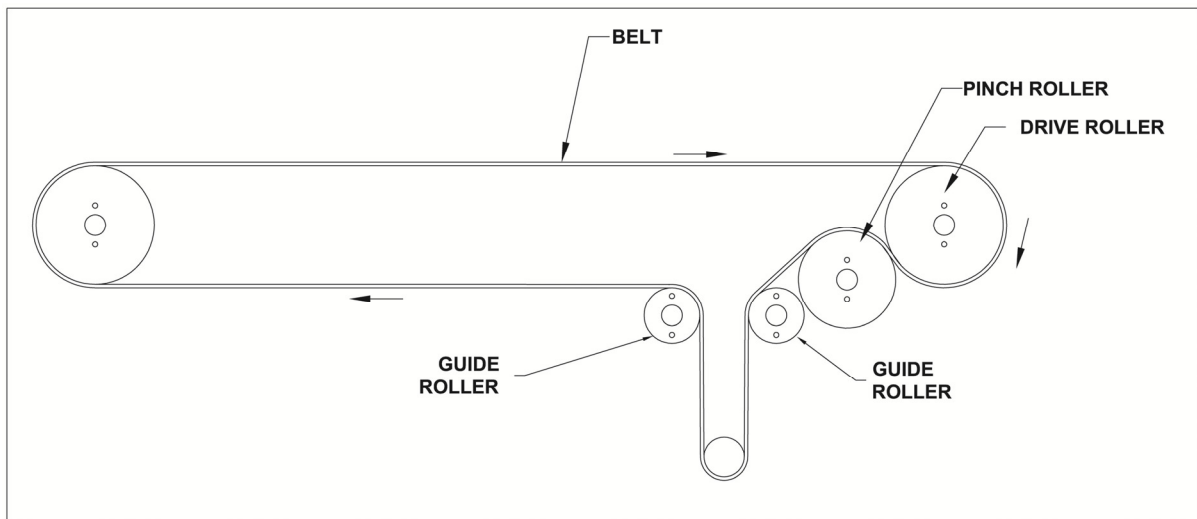

Figure 1-7 Belt Path

When installing the belt, have an assistant ready to help guide the belt into the furnace entrance.

A. Threading Belt

Extend a long wire or stick (to act as a pull rod) through the furnace chamber, being careful not to damage the lamps or insulation.

Securely attach the leading edge of the belt to the pull rod. Carefully pull the belt through the furnace from the exit end, while an assistant at the entrance unrolls and guides the belt into the furnace.

When the belt has been pulled through the furnace chamber, remove the pull rod and thread a pull wire through the rollers and drive drum, as shown in Figure 1-7. Pull the leading edge of the belt to the entrance and splice.

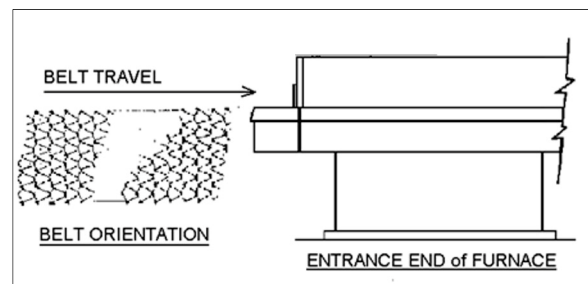

Figure 1-8 Belt Orientation

B. Splicing the Belt

Line up the ends of the belt so they are parallel and slightly overlapping.

Splice the belt by inserting one of the cross-section wires through the belt mesh across the width of the belt as shown in Figure 1-9.

The wire should be even and parallel and aligned with the belt edges. The cross-section wire will stay in place without any finishing at either end.

C. Belt Weight

Install belt weight as shown in Figure 1-12 and Figure 1-13

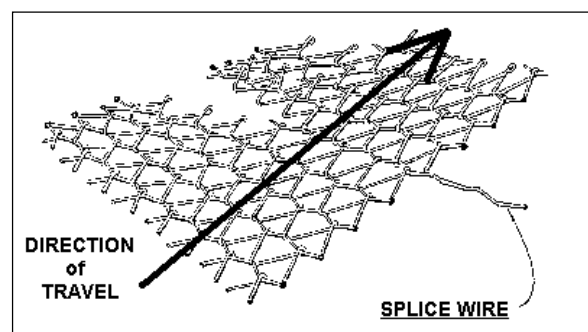

Figure 1-9 Belt Splice

1.2.3 Unpacking and Installation of Belt Weight

A. Locate and Unpack Belt Weight

Remove one of lower side panel near the furnace exit (below Control Enclosure). Using a flat screw driver turn the two latches to release and pull off the panel. This panel can be rotated and hung from the upper panel.

Locate the belt weight as shown in Figure 1-11 . Unwrap and remove packing.



Figure 1-10 Lower Access Panel

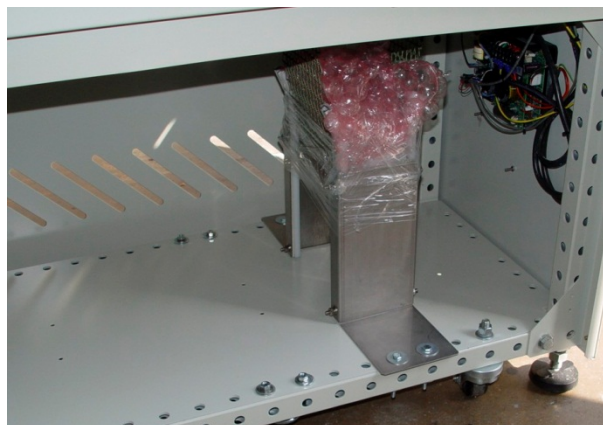

Figure 1-11 Belt Weight with packing

B. Install Belt Weight

Reinsert belt weight as shown in Figure 1-12. If necessary, pull belt to the left or right to align Belt so that Belt Weight is allowed to move freely as shown in Figure 1-13.



Figure 1-12 Belt Weight in Place

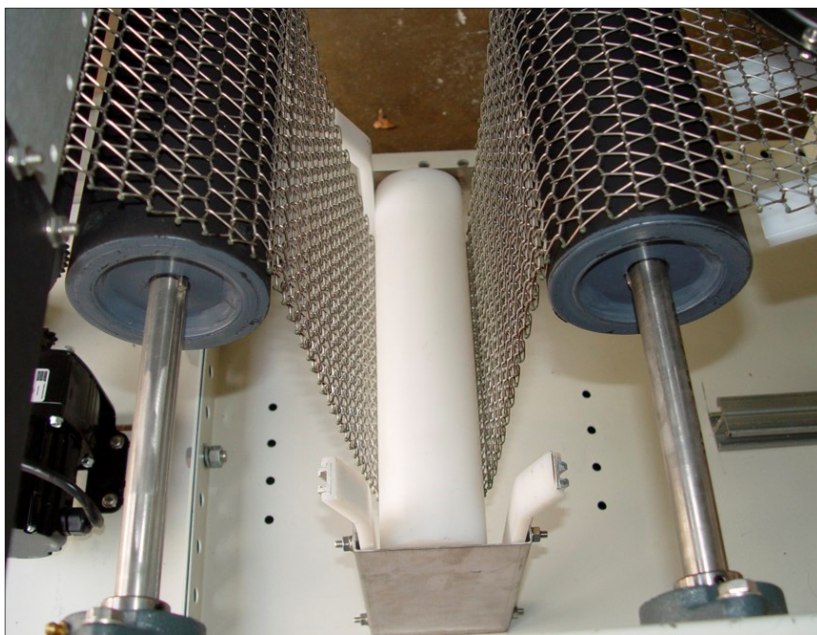

Figure 1-13 Proper Alignment of Belt Weight

1.3 Providing Power

The furnaces are shipped wired for the voltage specified on the nameplate. The nameplate is located either near where the power is to be connected typically either:

1. Adjacent to the power entrance hole in the lower electrical compartment near the contactor or circuit breaker, or



Figure 1-16 Elapsed Time Meter and Nameplate

2. For power supplied from the top of the furnace, the label shall generally be located on top of the furnace behind the top mounted enclosure closest to the supply power connection.

Depending on options supplied, Connect electrical power, matching the specifications on the nameplate to the circuit breaker, 3-phase disconnect switch, or TB-6 (on Safety Panel accessed via the furnace Panel Lower Rear Entrance panel through the Power Port shown on the Furnace Arrangement drawing per drawing 802-101770 POWER CONTROL SCHEMATIC.

A ground terminal is provided for a safety ground. All city and local codes should be followed when wiring this system for power. See Facilities drawing 803-091309 and Engineering and Specifications sections of this manual for power requirements.



Figure 1-14 Standard Front Entry Power Port and Elapsed Time Meter



Figure 1-15 Typical safety interlock disconnect switch location (option)

3-PHASE CIRCUIT BREAKER
POWER PORT KNOCKOUTS

PROCESS
GAS CONNECTION



Figure 1-17 Typical circuit breaker enclosure location (option)

1.3.1 Circuit Breaker (supplied option)

A 3-phase circuit breaker if supplied will be mounted in an enclosure on top of the furnace at the location shown on the Furnace Arrangement drawing. Wire supply power through one of the knockouts on the enclosure. All city and local codes should be followed when wiring this system for power. See Facilities drawing 803-091309 and Engineering and Specifications sections of this manual for power requirements.



Figure 1-18 Circuit Breaker enclosure



Figure 1-19 Circuit breaker

1.3.2 3-Phase Interlock Disconnect Switch (option, not supplied).

FURNACE Interlocked ON/OFF switch Equipment furnished with an interlock 3-phase disconnect requires connection to the terminal block in the provided disconnect enclosure. Remove the upper and lower panels, numbers 4 and 11 (ref 802-101401-01 PANEL LAYOUT). The disconnect switch must be turned to OFF to remove the lower panel.

Locate the disconnect enclosure behind the lower panel and remove its cover by loosening the two screws. Remove one of the knockouts in the top of the enclosure [use center 1" opening for four (4) #8 AWG wires or larger 1-1/4" knockout for up to four (4) #4 wires]. Pass the 3-phase power lines through the Power Port in the top of the furnace into the disconnect box.

Connect three phase power lines to the provided terminal blocks. Replace the cover and the panels, making sure to properly engage the disconnect switch with the protruding switch shaft. Startup technician will make final connection at the contactor.



Figure 1-20 Interlock Disconnect switch



Figure 1-21 Interlock disconnect switch enclosure

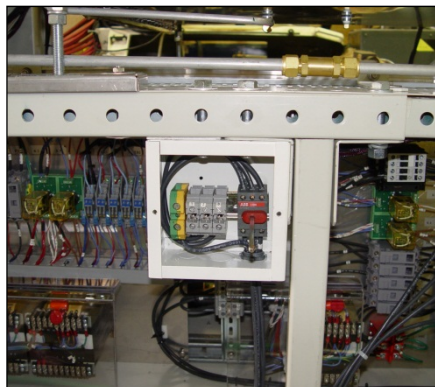

Figure 1-22 Enclosure, cover removed

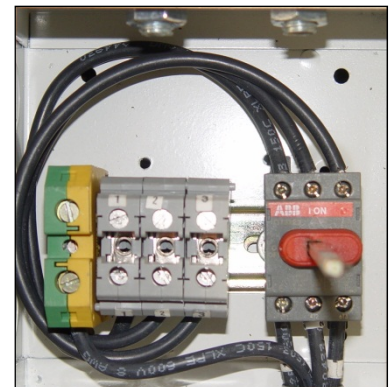
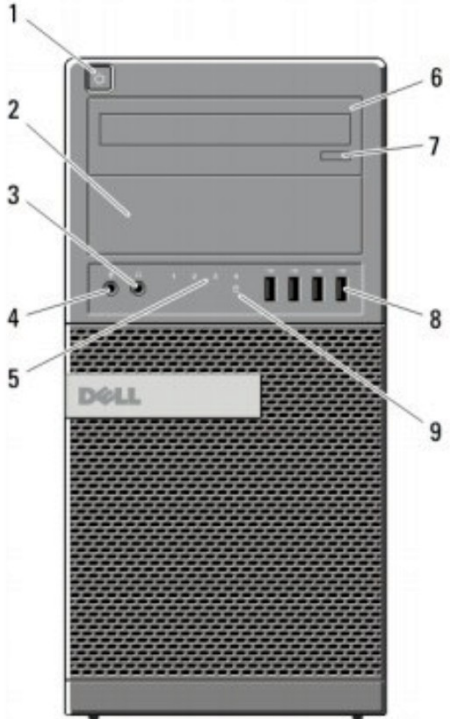
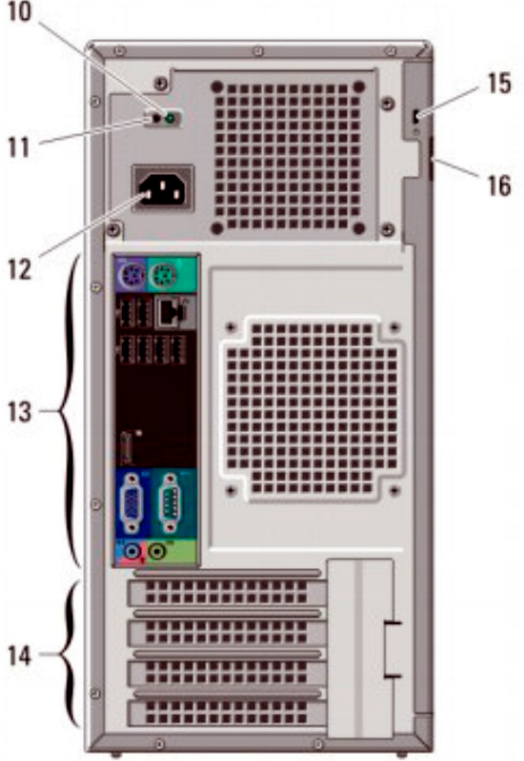
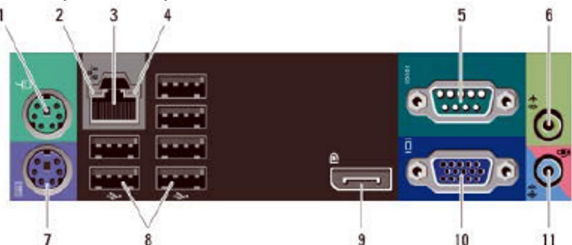

Figure 1-23 Disconnect switch & power connection terminal blocks

1.3.3 Computer Connections and Power Options

The furnace computer is powered whenever the furnace MAIN power light is on. In this mode the computer is prevented from inadvertent power down when the Furnace Power OFF button is pressed. Before starting the furnace, if the computer has been powered down, the Operator must open the computer access door and start the computer by pressing the power on button just before restart of the furnace. Furnace computer ports are shown in Figure 1-24. The computer may have a slightly different appearance.

Figure 1-24 Computer Ports

	
<p style="text-align: center;">Front view</p> <ol style="list-style-type: none"> 1. Power Button, Power Light 2. optional equipment 3. Headphone mini-port 4. Microphone mini-port 5. Diagnostic lights (4) 6. Optical Drive 7. Optical Drive Eject button 8. USB 2.0 connectors (4) 9. Drive activity indicator 	<p style="text-align: center;">Rear view</p> <p>1,5-7 not used.</p> <ol style="list-style-type: none"> 2-4 Furnace Controller Ethernet port 8. USB ports (6) 9. Display port 10. Power supply diagnostic light 11. Power supply diagnostic button 12. Power receptacle 13. Back Panel 14. Company network and wireless antenna expansion ports. 

1.3.4 Furnace Network Connections

Owner may connect the furnace to its network or the internet using either the RJ45 port located on the furnace Lower Entrance Panel with a Cat5e or Cat6 cable (see Figure 1-25)

The Ethernet port is the computer Local connection 2. In addition, the furnace is equipped to accept a wireless network connection. (see Figure 1-26)

The motherboard Local Area Connection (10.192.105.100, subnet 255.255.255.0) is reserved for the furnace controller.

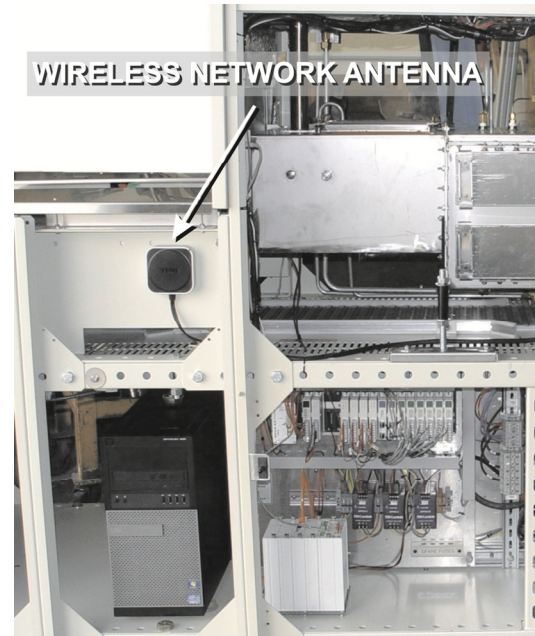

Figure 1-25 Wireless Network Antenna

1.3.5 Furnace USB Connections

The furnace is equipped with two (2) USB 2.0 ports installed at the entrance of the furnace to facilitate hookup of profiler equipment (Figure 1-26). Two (2) additional USB ports are located on the left-hand side of the Professional LCD monitor located above the control console. These USB ports can be used to archive or copy files to the furnace computer.

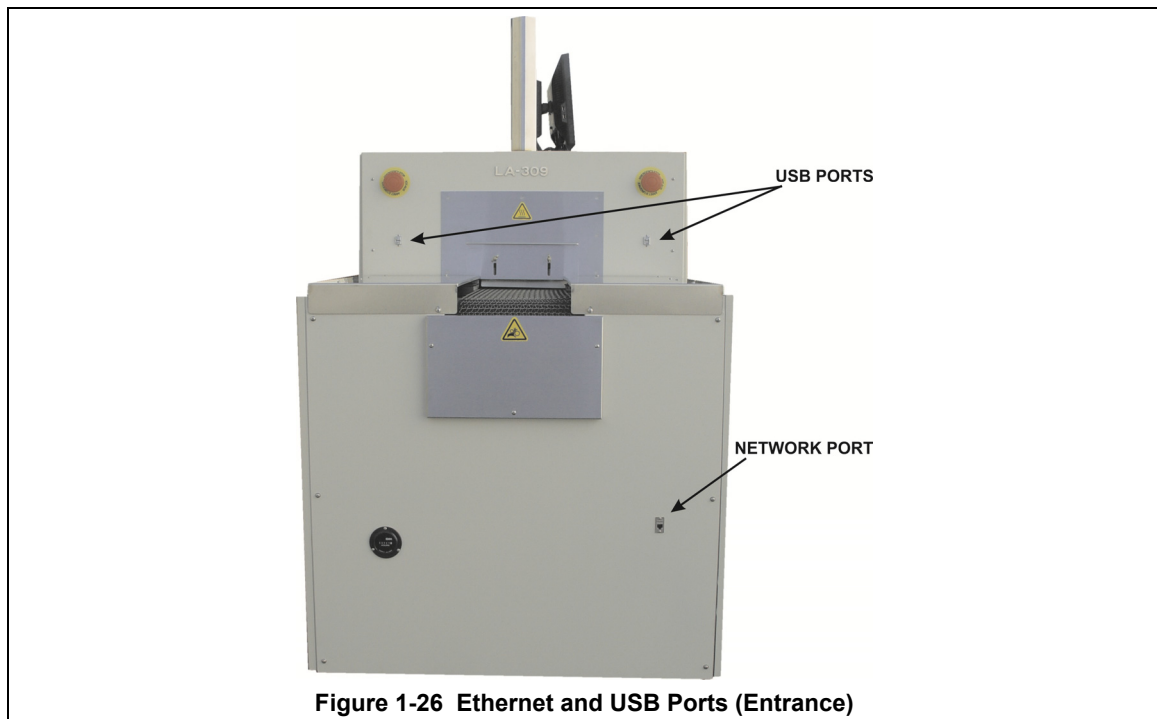

Figure 1-26 Ethernet and USB Ports (Entrance)

1.3.6 of Owner Supplied UPS

If desired a uninterruptible power supply (UPS) can be installed by FurnacePros, or the Owner. See Sections 4 and 5 for information on computer power requirements necessary for sizing the UPS.

To install the UPS, locate the lower access panel located near the entrance of the furnace on the side opposite the Control Console. Install the UPS in this area on the furnace floor panel so that it is well supported. Provide power to the UPS through the standard 117 Vac socket labeled “COMPUTER UNSWITCHED”. Plug the UPS serial or USB connector into the rear panel of the computer tower.

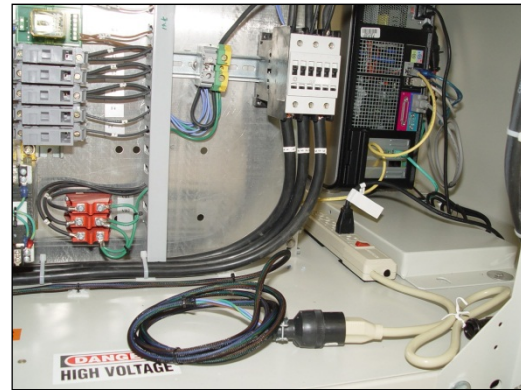

Figure 1-27 Computer “Unswitched”

To install the manufacturer’s software, insert the UPS Installation Disk in the optical drive accessed through the computer access opening below and left of the control console. Follow UPS manufacturer’s instructions for proper installation and configuration of the UPS to allow normal computer system shutdown in the event power is removed from the furnace system.

To install the UPS in Windows®7, start the computer and insert the UPS Installation Disk in the computer optical drive accessed through the computer access door below and to the right of the Control Console and follow the prompts.

To setup the UPS in Windows:

1. Click on Start/Control Panel
2. Select Power Options
3. Select the UPS tab.
4. Select manufacture and model buttons and enter preferences to allow normal computer system shutdown in the event power is removed from the furnace system.

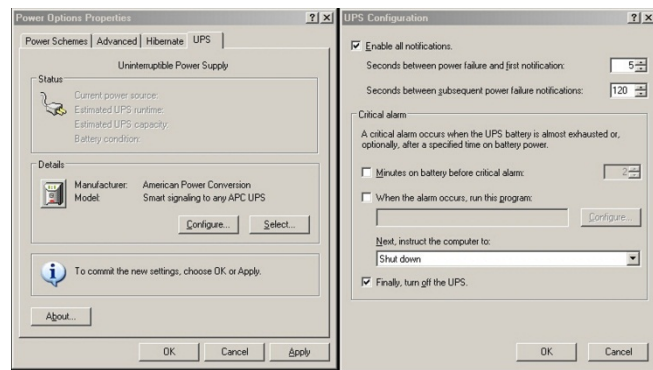

1.3.7 Product Handling (SMEMA) and Handshake (HSK) Connections

If so equipped, refer to drawing 803-101951 for SMEMA pinout information for connections at the entrance and exit.

If so equipped, refer to 803-101777 for handshake relay NO/NC connections at entrance and/or exit of the furnace.

1.4 Providing Process Gas

Oil-free dry process gas at a maximum recommended dew point of 15°C (59°F), shall be brought to the machine through a customer supplied lines with a minimum inside diameter of 3/4 inch. Initial supply pressure shall not exceed 175 psig. In addition to a supply line filters and condensate traps, regulators to reduce supply pressure to 70 psig must be installed on the supply line before entering the furnace.

The supply temperature of both gas and air should be above the dew point of the room air to prevent condensation from forming on the feed lines and dripping into the furnace.

See Furnace Arrangement drawing for location of process connections. An example of typical process air connection is shown in Figure 1-29 shows typical Nitrogen and Hydrogen gas connections to a mixing enclosure.

WARNING: The flowmeters on these furnaces are rated at 70 psi (5 bar) maximum. Operating above 70 psi exposes the operator to possible injury

1.4.1 Non-combustible Process Gas Exhaust Requirements

In most applications, process exhaust and heat is vented to the outside atmosphere. It is the customer's responsibility to review the process, local laws, and facility in deciding on an exhaust system.

The furnace exhaust stacks are 1.50 inch diameter inside a 3.00 inch diameter insulated shroud. Insulated exhaust tubing and an 8 inch inside diameter or larger collector hood is routinely used for non-combustible process gas.

Do not make any direct connections to the chamber exhaust stacks. A minimum 2.0 inch clearance between the 3.00 inch diameter exhaust stack shroud and the venting device is required. Figure 1-31 Exhaust Connection and Figure 1-32 Exhaust Connection Detail show typical exhaust connections for nitrogen, CDA and forming gas applications. Collector hoods are typically 8-10 inches diameter connected to a 4-6 inch diameter duct. Ducts from multiple stacks can be connected above. Butterfly dampers (shown) can be used to balance exhaust flow and to minimize facility exhaust system influence on the furnace atmosphere. Oil-free dry process gas at a maximum recommended dew point of 15°C (59°F), shall be brought to the machine through a customer supplied lines with a minimum inside diameter of 3/4 inch. Initial supply pressure shall not exceed 70 psig (except if optional supply gas Mixing System is included). In addition to a supply line filters and condensate traps, and regulators to reduce supply pressure to 70 psig must be installed on the supply line before entering the furnace.

WARNING: The flowmeters on these furnaces are rated at 70 psi maximum. Operating above 70 psi exposes the operator to possible injury

The supply temperature of any gas including air should be above the dew point of the room air to prevent condensation from forming on the feed lines and dripping into the furnace.

See 803-091309 Furnace Arrangement drawing for location of process connections. An example of typical process air connection is shown in Figure 1-28.



Figure 1-28 CDA Connection



Figure 1-29 H2 & N2 Connections

Section 1

1.4.2 Single Gas Furnaces

On single gas furnaces, Gas 1 is a $\frac{3}{4}$ inch female pipe connection for connecting CDA (clean dry compressed air) or nitrogen or other process gas to supply all furnace flowmeters on the front of the control console as well as providing pressure to the transport tensioning system.

1.4.3 Dual Gas Furnaces (option, not supplied)

On Dual Gas furnaces (optional), Gas 1 is a $\frac{3}{4}$ inch female pipe connection Gas 1 is the primary gas connection for CDA or nitrogen to all furnace auxiliaries including inlet and transition tunnel baffles, entrance exhaust stack eductor, lamp seals and CACT cooling chamber. Gas 1 also provides pressure to the transport tensioning system.

Gas 2 is a $\frac{3}{4}$ female pipe connection for nitrogen or forming gas supply to the furnace heating chambers.



DANGER: Except for furnaces specifically equipped with the hydrogen option, combustible gas should NOT be connect to the furnace. Forming gas or other gas mixtures which have a combustible gas component can be safely introduced into furnace provided the delivered concentration is below its lower flammable limit (LFL) in air.

1.4.4 Supply Gas Mixing System (option, not supplied)

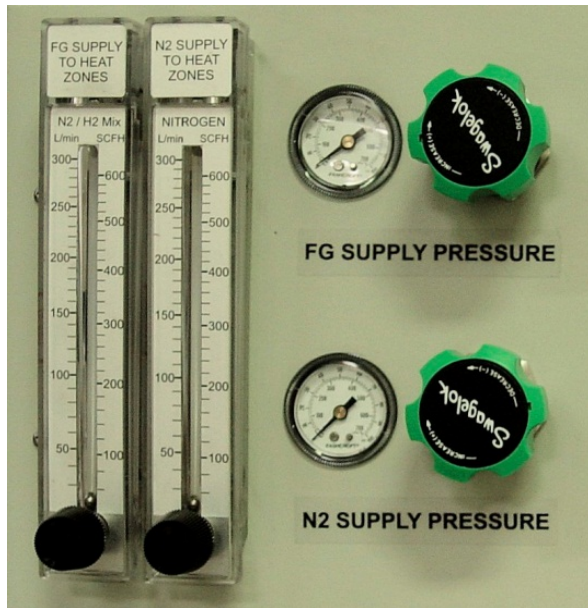

Figure 1-30 Supply Gas Mixing System

An option on Dual Gas furnaces, the Supply Gas Mixing System facilitates connection of two process gases which can then be alternatively selected or mixed while the furnace is operating.. In addition, the system includes two pressure regulators that can accept supply line pressures of from 100 psi – 3500 psi (6.5-240 bar). Pressure gauges in both lines allow the user to adjust the pressure on both lines to the pressure the furnace requires: 70 psig (4.8 bar).

Gas 1 is a $\frac{3}{4}$ inch female pipe connection for connecting nitrogen to all furnace auxiliaries including inlet and transition tunnel baffles, entrance exhaust stack eductor, lamp seals and CACT cooling chamber. In addition, this port feeds the N2 (Nitrogen) supply pressure gauge and flowmeter located on the side of the control console. Gas 1 also provides pressure to the transport tensioning system.

Gas 2 port is a $\frac{3}{4}$ female pipe connection for premixed FG (forming gas) supply. This port feeds the FG (N2/H2) premix supply pressure gauge and flowmeter on the side of the control console.

1.5 Exhaust Requirements

1.5.1 Cabinet Gas Exhaust Requirements

A 4-inch round duct with 8x12 inch rectangular hood can be installed above the 10-inch diameter cabinet cooling exhaust fan to reduce the additional heat load the furnace can add to its environment. The duct generally does not need to be insulated. As the cabinet fan only cools the cabinet interior, if the furnace is installed in an adequately ventilated room, this exhaust duct may not be required.

See 803-091309 FACILITY ARRANGEMENT drawing for suggested duct and hood locations.

1.5.2 Non-combustible Process Gas Exhaust Requirements

In most applications, process exhaust and heat is vented to the outside atmosphere. It is the customer's responsibility to review the process, local laws, and facility in deciding on an exhaust system. Insulated exhaust tubing and a collector hood, is routinely used for non-combustible process gas. Do not make any direct connections to the furnace exhaust stacks. A minimum 2.0 inch clearance between the 3-inch diameter exhaust stacks and venting hood or device is required. We recommend a 4-inch diameter insulated exhaust duct with an 8-inch diameter insulated hood.

Figure 1-31 Exhaust Connection and Figure 1-32 Exhaust Connection Detail show typical exhaust connections.

See 803-091309 FACILITY ARRANGEMENT drawing duct and hood location.



Figure 1-31 Exhaust Connection



Figure 1-32 Exhaust Connection Detail



Figure 1-33 Cabinet Exhaust Example



Figure 1-34 Cabinet Exhaust Examples

1.5.3 Combustible Process Gas Exhaust Requirements (hydrogen option only □)

In most applications, process exhaust and heat must be vented to the outside atmosphere. It is the user's responsibility to review the process, local laws, and facility in deciding on an exhaust system. If combustible gases are present, a wide collector hood suitable for 300°C operation with a 30-inch inside diameter, or larger, is routinely used. The hoods are typically located a minimum of 24 inches above each igniter stack. See Furnace Arrangement drawing for suggested sizes and locations.

Do not make any direct connections to any chamber exhaust stack. Clearance between the exhaust stacks and venting device is required. See Figure 1-35 for example of a typical hydrogen furnace exhaust connection.



Figure 1-35 Typical Hydrogen Furnace Process Gas Exhaust Connection

1.6 Water and Drain Connections

1.6.1 Water Supply and Drain Connections for UCD (option not supplied)

Furnaces equipped with an ultrasonic cleaner dryer (UCD) system will require the customer to connect clean water supply lines to the connections provided.

Pipe water supply connection through rectangular opening in lower panel similar as shown in Figure 1-. Supply pressure shall not exceed 100 psig. The furnace shall include a water pressure regulator to reduce water pressure to a maximum of 30 psig.

Drains. For UCD systems a drain line capable of intermittent flows of 40 gpm at 40 psi (5-10 minute durations) must be connected to the water drain connection. . See Furnace Arrangement drawing 803-091309 for connection locations, sizes and maximum and typical flow rates.

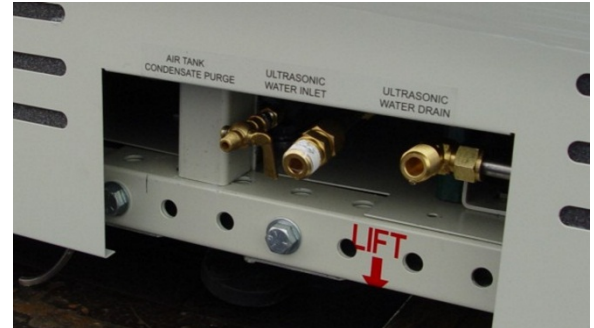

Figure 1-36 UCD Water Connections with Air Purge

1.6.2 Water Supply and Drain Connections for CAWC (option not supplied)

Optional Controlled Atmosphere Water Cooling (CAWC) systems require clean water supply supplied to the connections provided. Water cooling systems generally operate best when connected to a recirculating deionized water (DI) cooling system. Pipe water connection through rectangular opening in lower panel similar to Figure 1-37. Supply pressure shall not exceed 100 psig. Furnace includes dual pressure regulators to reduce water pressure to a maximum of 25 psig. . See Furnace Arrangement drawing 803-091309 for connection locations, sizes and maximum and typical flow rates.

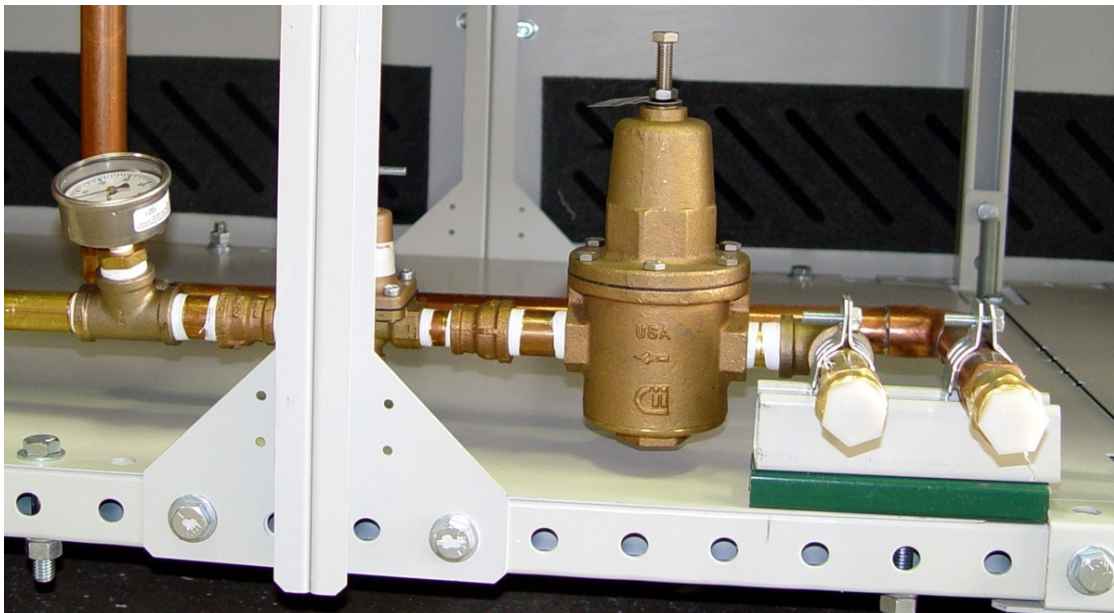

Figure 1-37 CAWC Water Supply & Drain Connections

Section 1

1.7 Emergency Machine Off (EMO)

Pressing these buttons, located at each end of the furnace, cuts all power to the machine circuits immediately. Rotating the button CW and pulling outward will reset the button. Both buttons must be in the SET position for power to enter the furnace.

Note: These buttons are for emergency use only and are not recommended for routine shutdown of the furnace.



Figure 1-38 EMO buttons at Entrance

1.8 Interlocks

There are electrical interlocks on the furnace on the entrance furnace lower side covers opposite the heating chamber. Figure Figure 1-39 shows the location on the front of the furnace below the control console. Another interlock switch is located in the same position on the rear side of the furnace.

Both the furnace side covers should be in place for power to enter the furnace in normal operation. Removing one of the panels will cause the interlocks to cut all power to the furnace. This is a safety precaution for your protection as both 117 Vac and 3-phase power circuitry and connections are inside the cavity.

Except when in placed into maintenance mode by qualified technicians, the lower panels should always be in place while power is being applied to the furnace. Trained personnel with a good understanding of the dangers involved may choose to override the interlocks by pulling outward on the interlock shaft to the “maintenance” position which will restore power to the furnace with the control box covers removed.

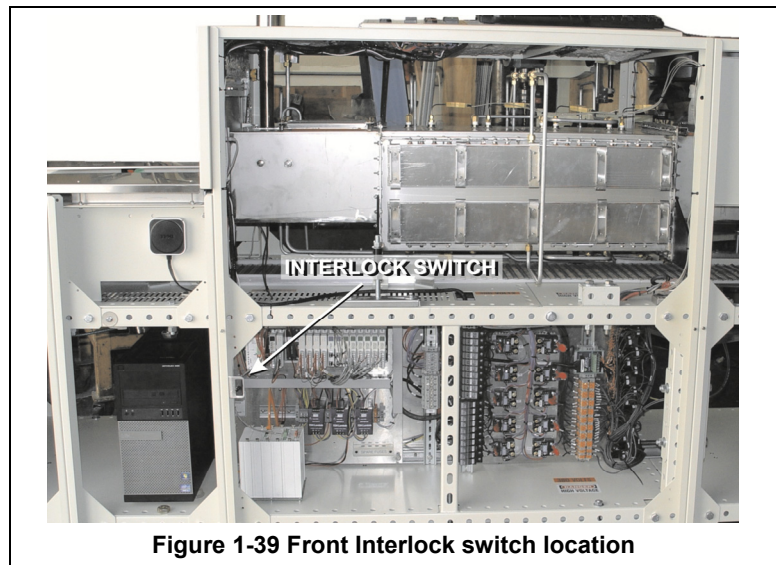

Figure 1-39 Front Interlock switch location

Warning: Dangerous voltage and current (potentially lethal) may be present in the control box with the interlocks in “maintenance” position.

1.9 Installation Responsibilities

1.9.1 Owner's Responsibility

Prior to Startup, it is the Owner's responsibility to accomplish the Installation tasks described in sections 1.1 through 1.8 as applicable.

For larger furnaces, FurnacePros shall reassemble, re-install the belt and level the furnace once it has been located at the site before any utilities can be connected.

When the LCI FurnacePros Technical Support or Service technician visits the user's plant, the technician will require the help of at least one customer representative who will be responsible for the operation and maintenance of the furnace system.

1.9.2 Pre-Installation Tasks by Owner

Tasks typically performed by the customer after furnace is assembled in place:

- Uncrate Furnace.
- Remove packing materials.
- Inspect for damage.
- Mover furnace or furnace sections and accessories to operating location.
- Provide utilities to general furnace location (gas, power, drains-if required, exhaust).
-

1.9.3 Installation Tasks by Manufacturer

Tasks typically performed by the LCI FurnacePros Field Service representatives before customer utilities can be connected include:

- Remove shipping restraints.
- Reassemble split furnace sections.
- Check for loose fasteners and fittings.
- Install computer system
- Seal furnace enclosure.
- Reinstall (split machines only) and align belt.
- Level furnace and furnace chamber sections.

1.9.4 Installation Tasks by Owner

Tasks typically performed by the customer after the furnace is assembled in place:

- Connect furnace power.
- Connect process gas piping.
- Connect water and drain lines (if required).
- Locate and install exhaust system.
- Locate and install upstream and downstream process equipment (optional).

Section 1

1.10 Initial Startup Tasks

Tasks typically performed during startup by the LCI FurnacePros Field Service representatives include:

- Checkout before first operation.
 - Verify transformer settings for customer supply power. Connect disconnect switch to main contactor to engage customer supply power.
 - Verify gas supply and water hookup and regulator pressure settings.
- Apply power, run through the installation checkout and test procedure:
 - Check/confirm voltages.
 - Verify all fans are operating
 - Verify belt tracking.
 - Check operation of cooling system
 - Leak check water system
 - Verify flowmeter settings
 - Leak check process gas system.
- Troubleshoot and systems test:
 - Process Gas systems check
 - O2 & Moisture analyzer check (option)
 - OSS check (gas sampling system option)
 - SMEMA or SENSLAS product alert and handling check (option)
 - Transport motion alarms check
 - Element monitoring system check
 - Software integration test
- Cycle machine to a fully operational state & Calibrate:
 - Power up
 - Check heating and cooling sequence
 - Check standard alarm systems
 - Re-calibrate belt.
 - Re-calibrate all SCR's
 - Run furnace READY stabilization check
- Report to the customer any deficiencies noted in the installation of the machine.
- Instruct the appropriate personnel in the customer's plant how to operate the furnace system.
- If training has been included, a manufacturer's representative shall train the appropriate personnel in the customer's plant on furnace operation and necessary preventive maintenance.
- Owner preferences:
 - Archive furnace profile default settings.
- Replace Covers. Before operation for production, install any covers that were removed during the functional checkout.

NOTE: All functions must operate properly before proceeding. Refer to the Service Information section and correct any malfunctions before completion.

- Turn over the machine and documentation to the customer.